

VL6180X

3-in-1 time-of-flight module: proximity sensor, ALS and gesture



VL6180X combines a light source, proximity sensor and ambient light sensor (ALS) in a single integrated module

The VL6180X is the latest product based on ST's patented FlightSense™ technology. The VL6180X module uses the time-of-flight measurement principle to implement a proximity sensor, offering significant advantages over conventional infra-red (IR) technology. The module also includes an ambient light sensor.

KEY BENEFITS

- Fully integrated module : IR emitter, Ranging sensor and ALS. No need of external LEDs
- SPAD array based (single photon avalanche diode) : unique product on market
- Absolute distance measurement (in millimeters, register output)
- Accurate and low power (early convergence mode or continuous mode)
- Independent of target reflectance : work with dark colours, gloves, ...

TARGETED APPLICATIONS

- Mobile devices
 - Proximity detection
 - Ambient light sensing
 - 1D gesture control
- Domestic appliances
 - Power on/off, volume +/-
 - Liquid level monitoring or selection
 - Collision avoidance for cleaning robots (wall and cliff)
- Industrial
 - Object detection and ranging
 - Human-machine interface



SYSTEM ARCHITECTURE

The VL6180X contains an array of SPAD (Single Photon Avalanche Diode) detectors. The SPAD array forms part of an advanced system architecture that can detect the arrival of individual photons and hence calculate the time taken for the photon to leave the module, hit the target and then return back to the module. Actual distance measurement combined with signal amplitude allows simple but robust gesture recognition to enable multiple use cases.

Furthermore the VL6180X's ultra-low-power system architecture is perfectly suited to the demanding requirements of wireless and consumer products.

MODULE DESIGN

All components to support the proximity sensor and ambient light sensor are embedded in the simple optical module. No mechanical gaskets or additional lens systems are required to complete the industrial design.

The module can be mounted on the host PCB using a standard reflow profile or flex attached.

Its unique time-of-flight properties allow the module to be hidden behind a wide variety of cover-glass materials. This enables very innovative product design with the possibility of removing the hole that normally forms part of the industrial design.

SYSTEM BLOCK DIAGRAM

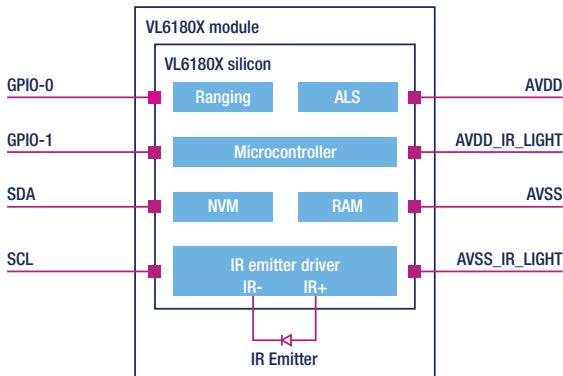

TIME-OF-FLIGHT PRINCIPLE

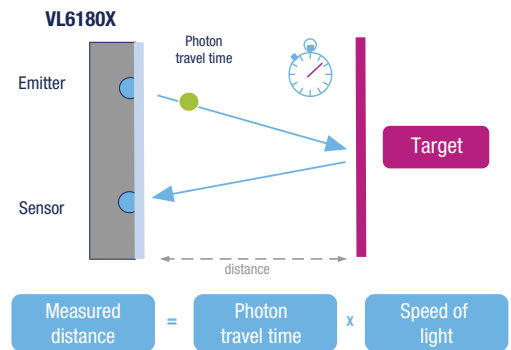

VL6180X MODULE



VL6180X EXPLORER KIT

Evaluation and development kit
order code : EVALKIT-VL6180X



STM32 Nucleo F401RE board
+
VL6180X expansion board

PRODUCT DETAILS

Part number	Package size	Operating range	ALS range	Power consumption	Supply voltage	Optimum operating temperature
VL6180XV0NR/1	4.8 x 2.8 x 1 mm	0 to 10 cm up to 40 cm ⁽¹⁾	< 1 Lux up to 100 kLux	Standby: < 1 µA ALS: < 300 µA (active) Ranging: 30µA (low power) to 1.7 mA (active) ⁽²⁾	2.6 to 3.0 V	-20 to +70 °C

Notes:

(1) with calibration depending on final application and hardware

(2) Typical average assuming 10 Hz, 17% reflective target at 50 mm



Need more details?

Flash me! www.st.com/vl6180x

Please visit our e2e community proximity sensors forum



© STMicroelectronics - September 2014 - Printed in United Kingdom - All rights reserved
The STMicroelectronics corporate logo is a registered trademark of the STMicroelectronics group of companies
All other names are the property of their respective owners

